

Local Area Network Overview

LAN Applications (1)

- Personal computer LANs
 - Low cost
 - Limited data rate
- Back end networks
 - Interconnecting large systems (mainframes and large storage devices)
 - High data rate
 - High speed interface
 - Distributed access
 - Limited distance
 - Limited number of devices

LAN Applications (2)

- Storage Area Networks
 - Separate network handling storage needs
 - Detaches storage tasks from specific servers
 - Shared storage facility across high-speed network
 - Hard disks, tape libraries, CD arrays
 - Improved client-server storage access
 - Direct storage to storage communication for backup
- High speed office networks
 - Desktop image processing
 - High capacity local storage
- Backbone LANs
 - Interconnect low speed local LANs
 - Reliability
 - Capacity
 - Cost

Storage Area Networks

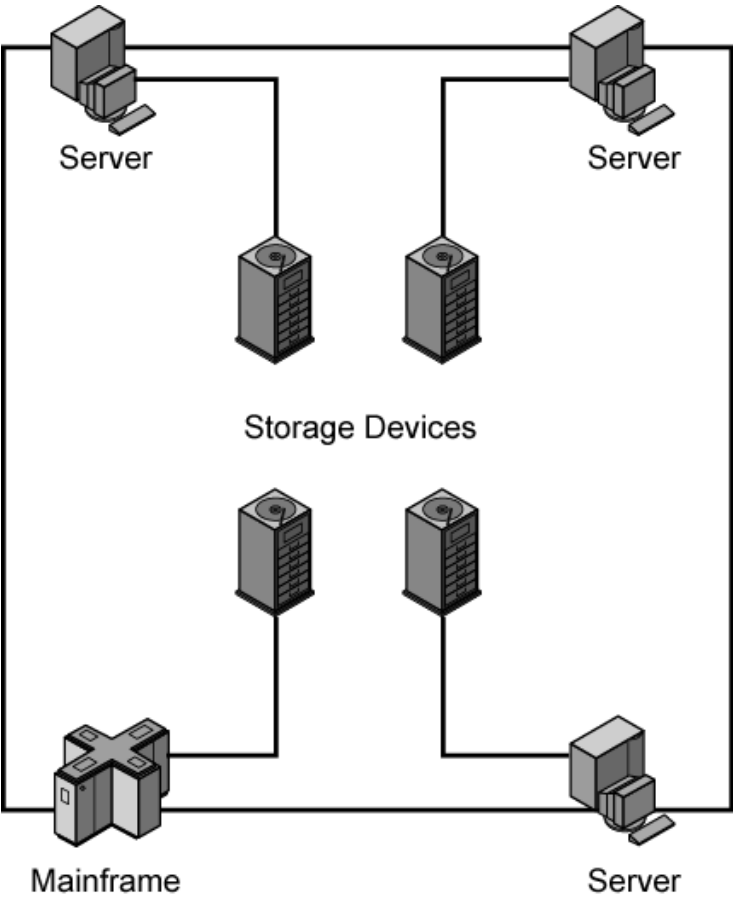

(a) Server-based storage

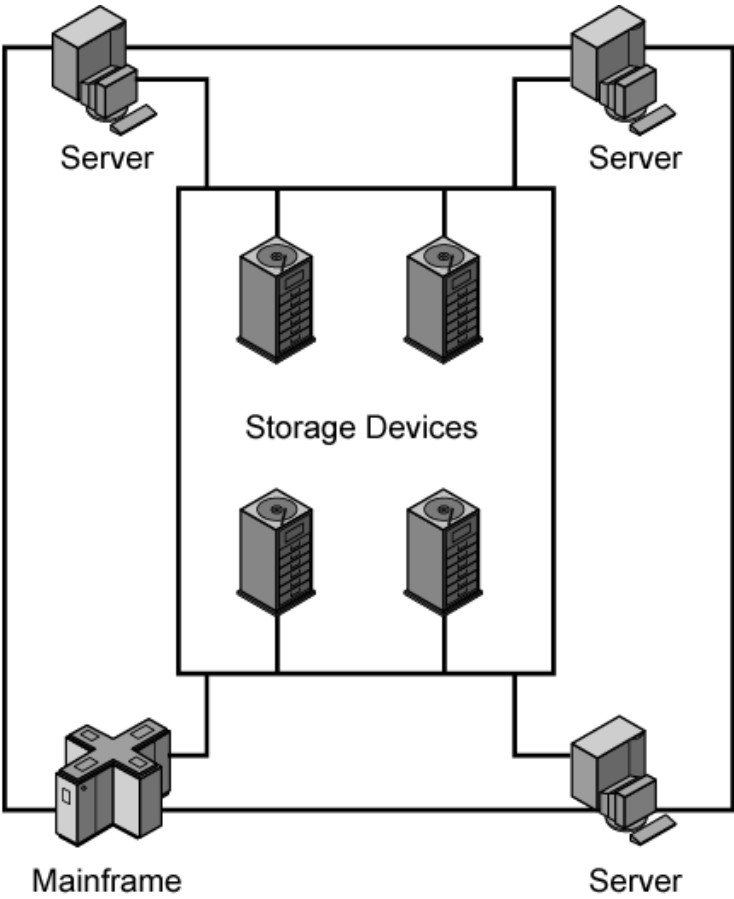

(b) Storage area network

LAN Architecture

- Topologies
- Transmission medium
- Layout
- Medium access control

Topologies

- Tree
- Bus
- Ring
- Star

LAN Topologies

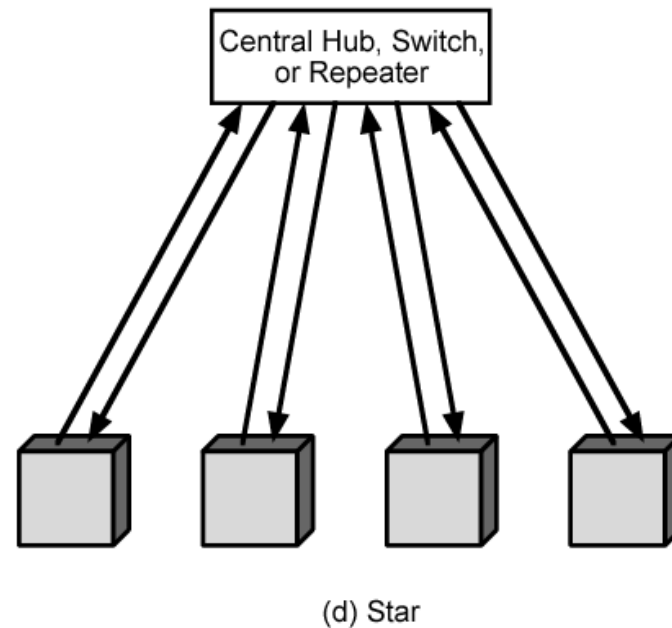
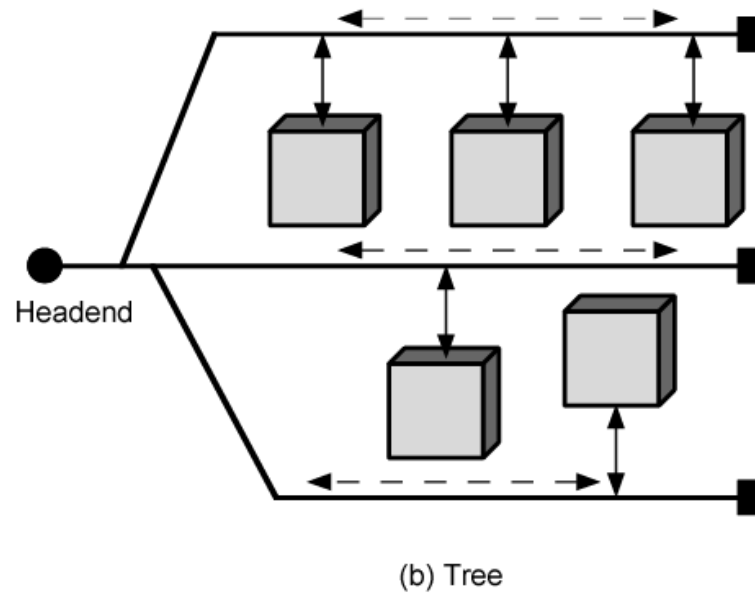
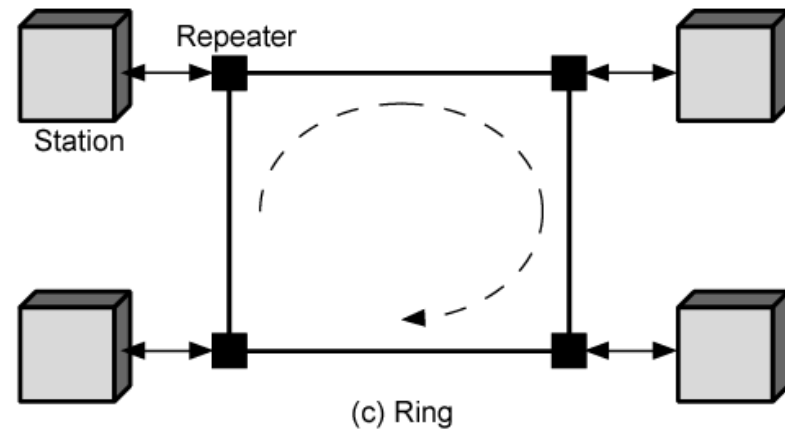
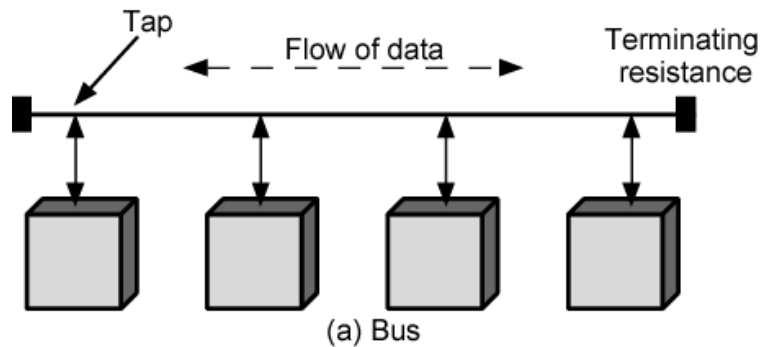

Bus and Tree

- Multipoint medium
- Transmission propagates throughout medium
- Heard by all stations
 - Need to identify target station
 - Each station has unique address
- Full duplex connection between station and tap
 - Allows for transmission and reception
- Need to regulate transmission
 - To avoid collisions
 - To avoid hogging
 - Data in small blocks - frames
- Terminator absorbs frames at end of medium

Frame Transmission on Bus LAN

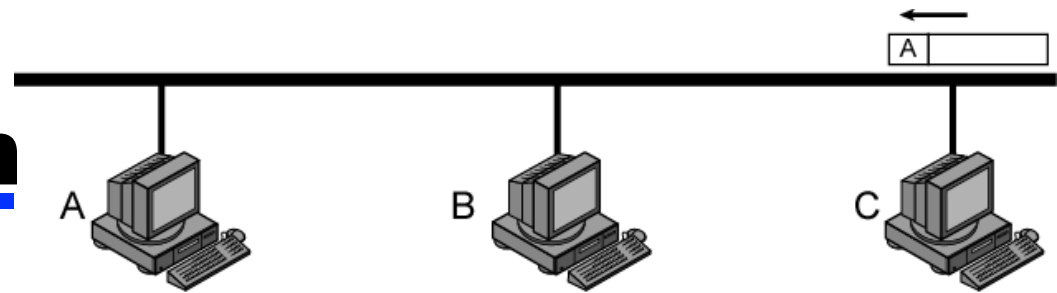

C transmits frame addressed to A

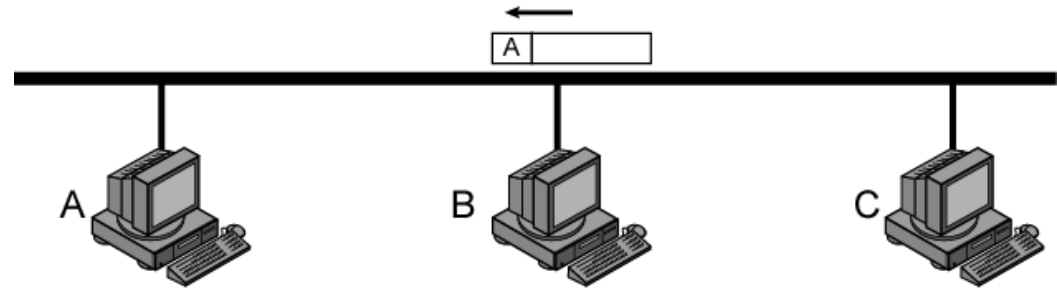

Frame is not addressed to B; B ignores it

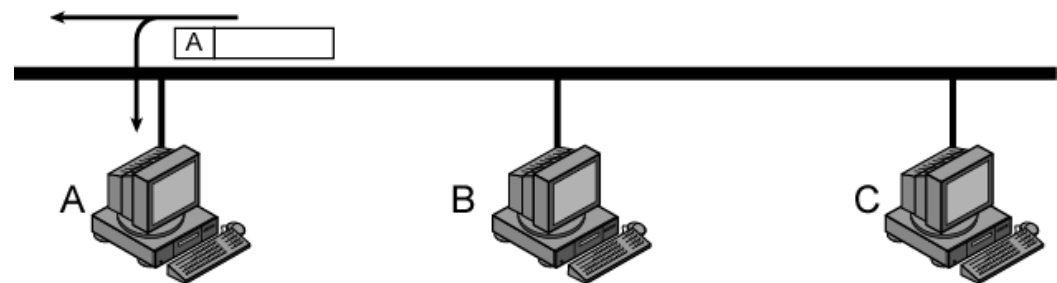

A copies frame as it goes by

Ring Topology

- Repeaters joined by point to point links in closed loop
 - Receive data on one link and retransmit on another
 - Links unidirectional
 - Stations attach to repeaters
- Data in frames
 - Circulate past all stations
 - Destination recognizes address and copies frame
 - Frame circulates back to source where it is removed
- Media access control determines when station can insert frame

Frame Transmission Ring LAN

(a) C transmits frame addressed to A

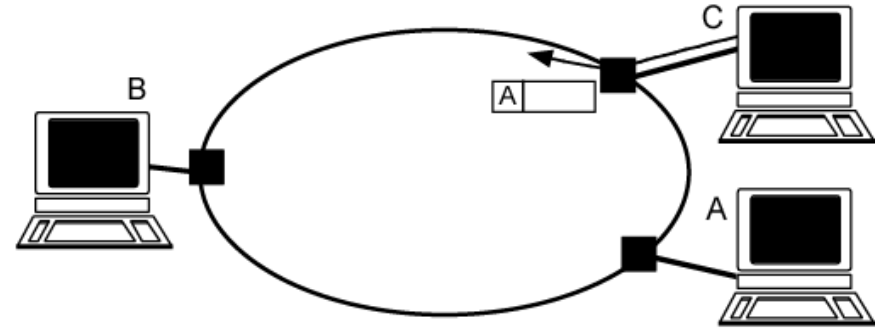

(b) Frame is not addressed to B; B ignores it

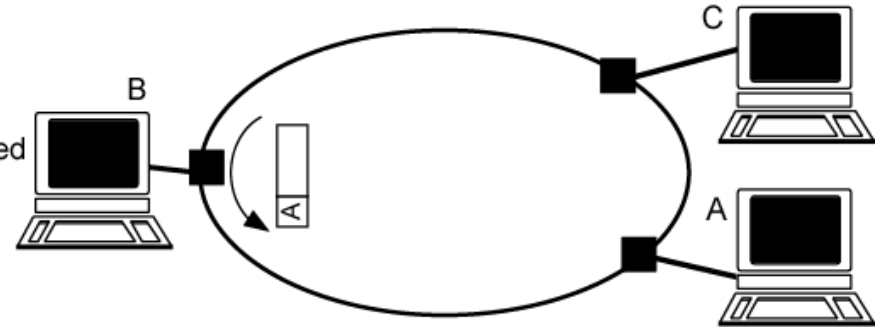

(c) A copies frame as it goes by

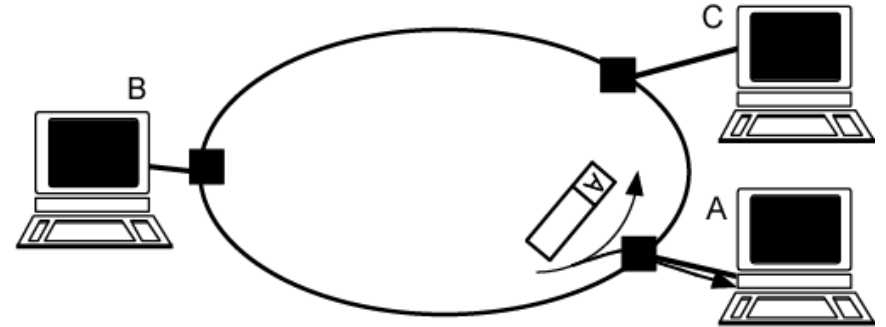

(d) C absorbs returning frame

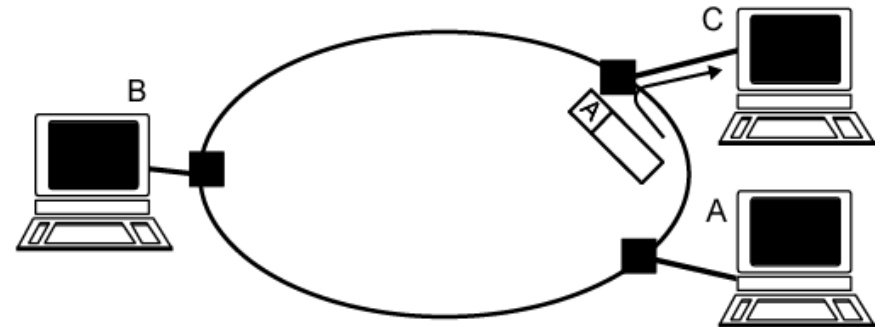

Star Topology

- Each station connected directly to central node
 - Usually via two point to point links
- Central node can broadcast
 - Physical star, logical bus
 - Only one station can transmit at a time
- Central node can act as frame switch

Choice of Topology

- Reliability
- Expandability
- Performance
- Needs considering in context of:
 - Medium
 - Wiring layout
 - Access control

Bus LAN

Transmission Media (1)

- Twisted pair
 - Early LANs used voice grade cable
 - Didn't scale for fast LANs
 - Not used in bus LANs now
- Baseband coaxial cable
 - Uses digital signalling
 - Original Ethernet

Bus LAN

Transmission Media (2)

- Broadband coaxial cable
 - As in cable TV systems
 - Analog signals at radio frequencies
 - Expensive, hard to install and maintain
 - No longer used in LANs
- Optical fiber
 - Expensive taps
 - Better alternatives available
 - Not used in bus LANs
- All hard to work with compared with star topology twisted pair
- Coaxial baseband still (rarely) used but not often in new installations

Ring and Star Usage

- Ring
 - Very high speed links over long distances
 - Single link or repeater failure disables network
- Star
 - Uses natural layout of wiring in building
 - Best for short distances
 - High data rates for small number of devices

Choice of Medium

- Constrained by LAN topology
- Capacity
- Reliability
- Types of data supported
- Environmental scope

Media Available (1)

- Voice grade unshielded twisted pair (UTP)
 - Cat 3
 - Cheap
 - Well understood
 - Use existing telephone wiring in office building
 - Low data rates
- Shielded twisted pair and baseband coaxial
 - More expensive than UTP but higher data rates
- Broadband cable
 - Still more expensive and higher data rate

Media Available (2)

- High performance UTP
 - Cat 5 and above
 - High data rate for small number of devices
 - Switched star topology for large installations
- Optical fiber
 - Electromagnetic isolation
 - High capacity
 - Small size
 - High cost of components
 - High skill needed to install and maintain
 - Prices are coming down as demand and product range increases

Protocol Architecture

- Lower layers of OSI model
- IEEE 802 reference model
- Physical
- Logical link control (LLC)
- Media access control (MAC)

IEEE 802 v OSI

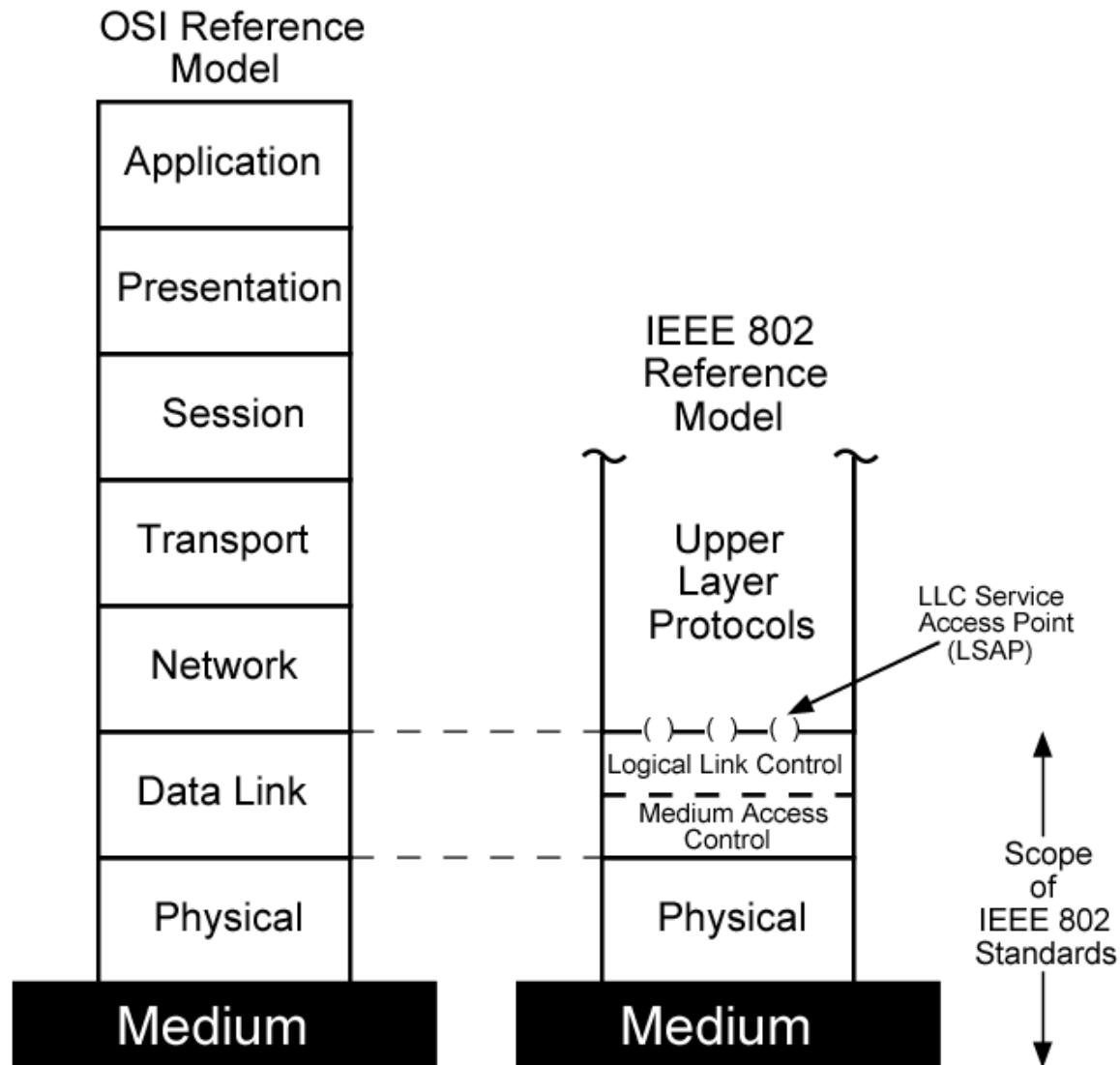

802 Layers - Physical

- Encoding/decoding
- Preamble generation/removal
- Bit transmission/reception
- Transmission medium and topology

802 Layers - Logical Link Control

- Interface to higher levels
- Flow and error control

Logical Link Control

- Transmission of link level PDUs between two stations
- Must support multi-access, shared medium
- Relieved of some link access details by MAC layer
- Addressing involves specifying source and destination LLC users
 - Referred to as service access points (SAP)
 - Typically higher level protocol

LLC Services

- Based on HDLC
- Unacknowledged connectionless service
- Connection mode service
- Acknowledged connectionless service

LLC Protocol

- Modeled after HDLC
- Asynchronous balanced mode to support connection mode LLC service (type 2 operation)
- Unnumbered information PDUs to support Acknowledged connectionless service (type 1)
- Multiplexing using LSAPs

Media Access Control

- Assembly of data into frame with address and error detection fields
- Disassembly of frame
 - Address recognition
 - Error detection
- Govern access to transmission medium
 - Not found in traditional layer 2 data link control
- For the same LLC, several MAC options may be available

LAN Protocols in Context

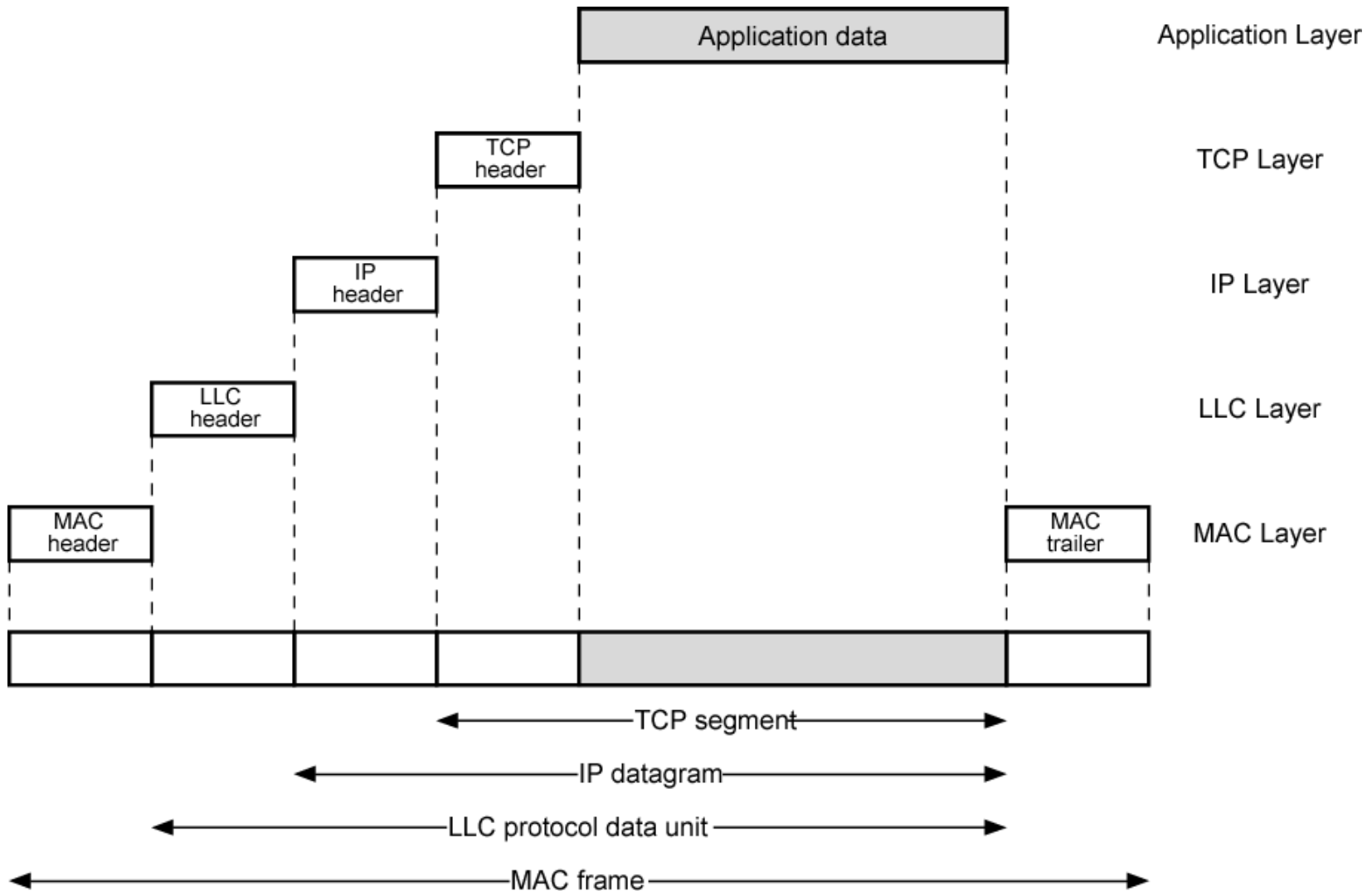

Media Access Control

- Where
 - Central
 - Greater control
 - Simple access logic at station
 - Avoids problems of co-ordination
 - Single point of failure
 - Potential bottleneck
 - Distributed
- How
 - Synchronous
 - Specific capacity dedicated to connection
 - Asynchronous
 - In response to demand

Asynchronous Systems

- Round robin
 - Good if many stations have data to transmit over extended period
- Reservation
 - Good for stream traffic
- Contention
 - Good for bursty traffic
 - All stations contend for time
 - Distributed
 - Simple to implement
 - Efficient under moderate load
 - Tend to collapse under heavy load

MAC Frame Format

- MAC layer receives data from LLC layer
- MAC control
- Destination MAC address
- Source MAC address
- LLS
- CRC
- MAC layer detects errors and discards frames
- LLC optionally retransmits unsuccessful frames

Generic MAC Frame Format

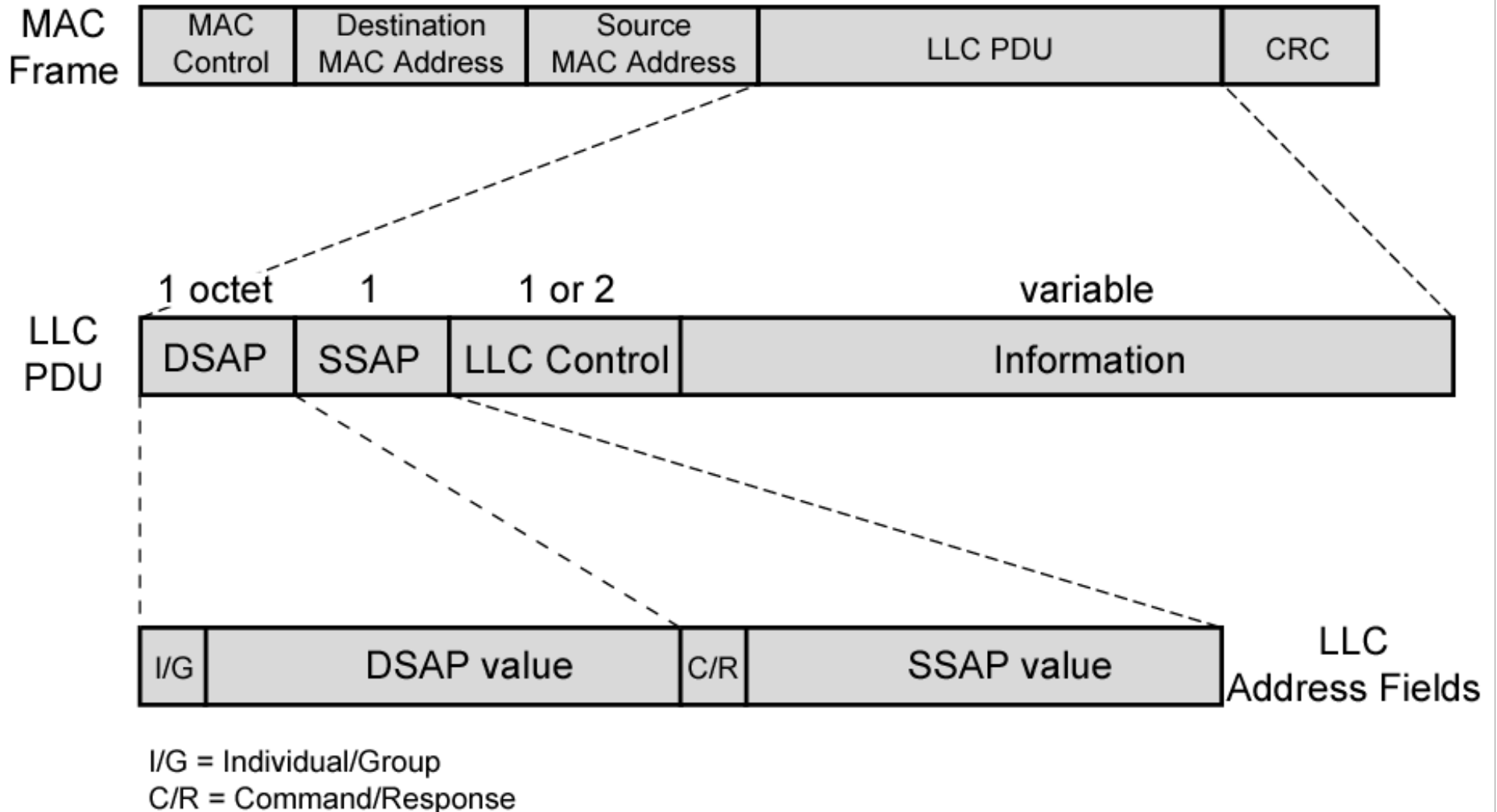

Bridges

- Ability to expand beyond single LAN
- Provide interconnection to other LANs/WANs
- Use Bridge or router
- Bridge is simpler
 - Connects similar LANs
 - Identical protocols for physical and link layers
 - Minimal processing
- Router more general purpose
 - Interconnect various LANs and WANs
 - see later

Why Bridge?

- Reliability
- Performance
- Security
- Geography

Functions of a Bridge

- Read all frames transmitted on one LAN and accept those address to any station on the other LAN
- Using MAC protocol for second LAN, retransmit each frame
- Do the same the other way round

Bridge Operation

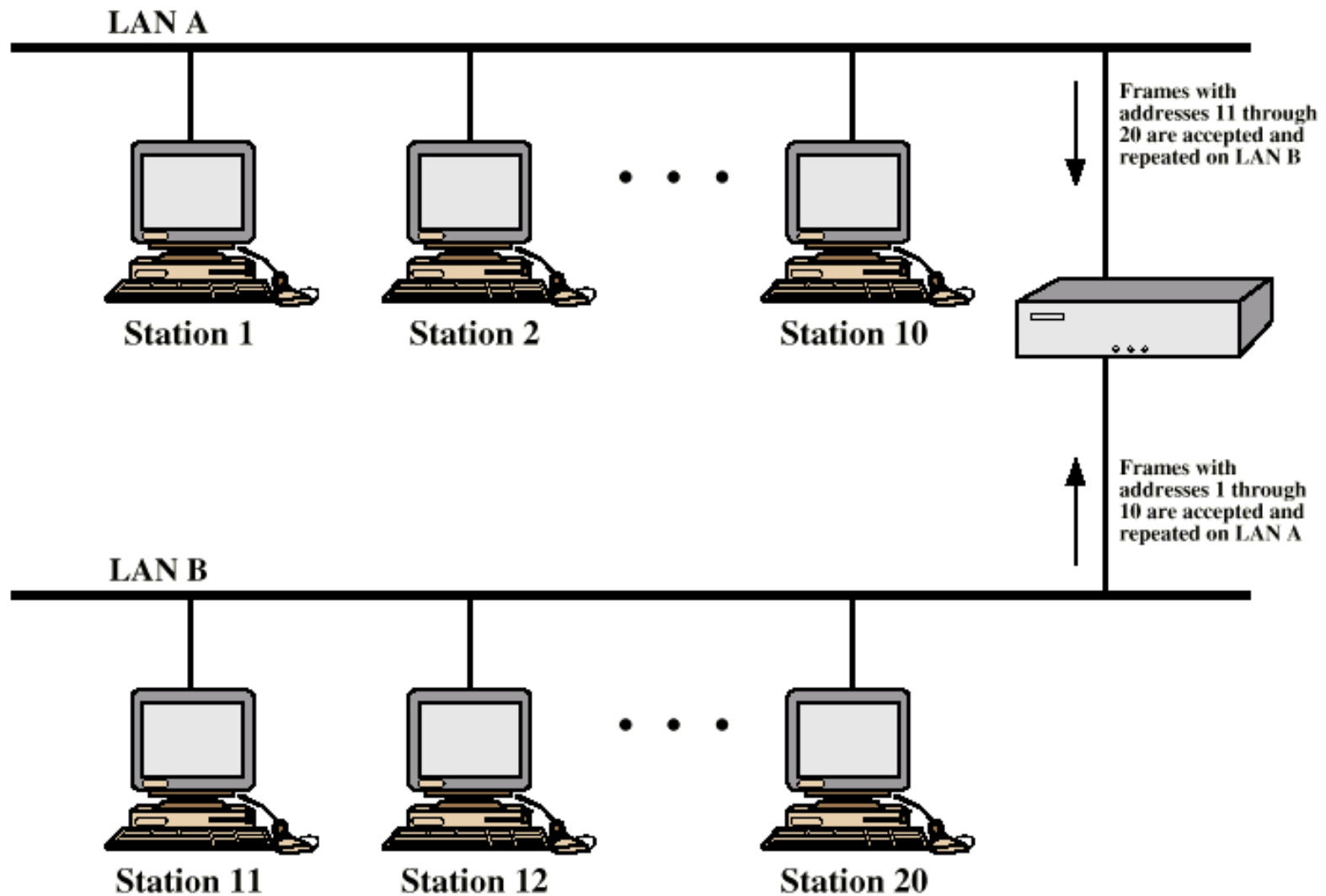

Bridge Design Aspects

- No modification to content or format of frame
- No encapsulation
- Exact bitwise copy of frame
- Minimal buffering to meet peak demand
- Contains routing and address intelligence
 - Must be able to tell which frames to pass
 - May be more than one bridge to cross
- May connect more than two LANs
- Bridging is transparent to stations
 - Appears to all stations on multiple LANs as if they are on one single LAN

Bridge Protocol Architecture

- IEEE 802.1D
- MAC level
 - Station address is at this level
- Bridge does not need LLC layer
 - It is relaying MAC frames
- Can pass frame over external communication system
 - e.g. WAN link
 - Capture frame
 - Encapsulate it
 - Forward it across link
 - Remove encapsulation and forward over LAN link

Connection of Two LANs

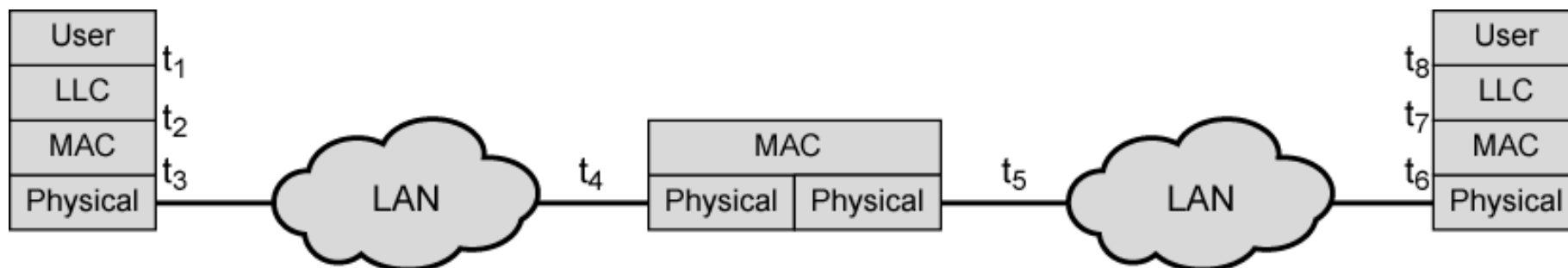

(a) Architecture

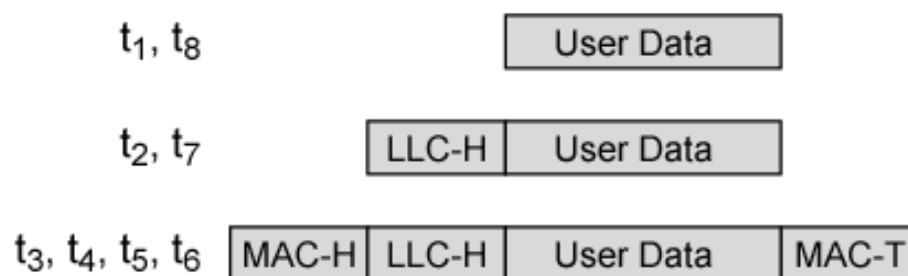

(b) Operation

Fixed Routing

- Complex large LANs need alternative routes
 - Load balancing
 - Fault tolerance
- Bridge must decide whether to forward frame
- Bridge must decide which LAN to forward frame on
- Routing selected for each source-destination pair of LANs
 - Done in configuration
 - Usually least hop route
 - Only changed when topology changes

Bridges and LANs with Alternative Routes

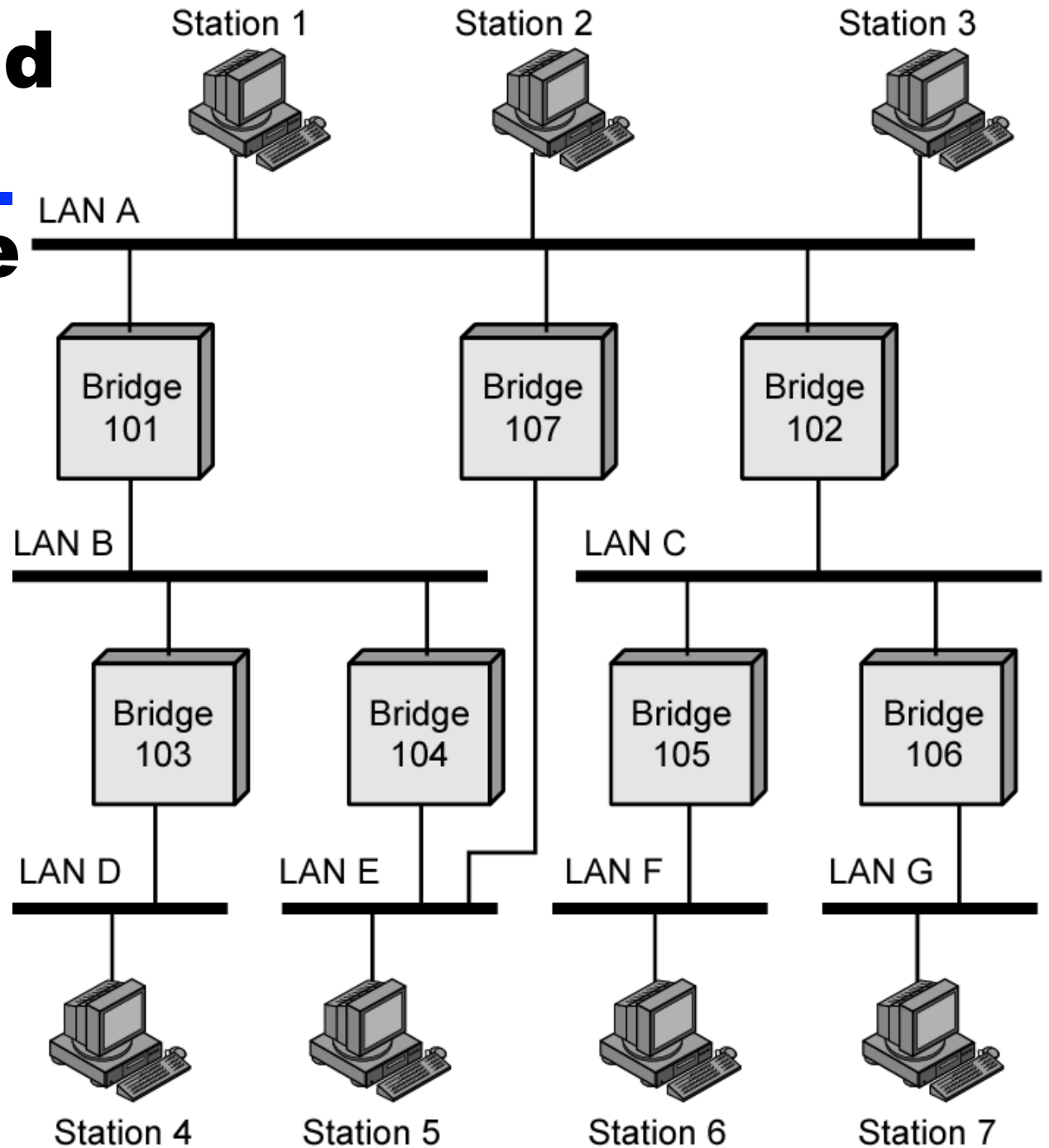

Spanning Tree

- Bridge automatically develops routing table
- Automatically update in response to changes
- Frame forwarding
- Address learning
- Loop resolution

Frame forwarding

- Maintain forwarding database for each port
 - List station addresses reached through each port
- For a frame arriving on port X:
 - Search forwarding database to see if MAC address is listed for any port (except port X)
 - If address not found, forward to all ports (except X)
 - If address listed for port Y, check port Y for blocking or forwarding state
 - Blocking prevents port from receiving or transmitting
 - If not blocked, transmit frame through port Y

Address Learning

- Can preload forwarding database
- Can be learned
- When frame arrives at port X, it has come from the LAN attached to port X
- Use the source address to update forwarding database for port X to include that address
- Timer on each entry in database
- Each time frame arrives, source address checked against forwarding database

Spanning Tree Algorithm

- Address learning works for tree layout
 - i.e. no closed loops
- For any connected graph there is a spanning tree that maintains connectivity but contains no closed loops
- Each bridge assigned unique identifier
- Exchange between bridges to establish spanning tree

Loop of Bridges

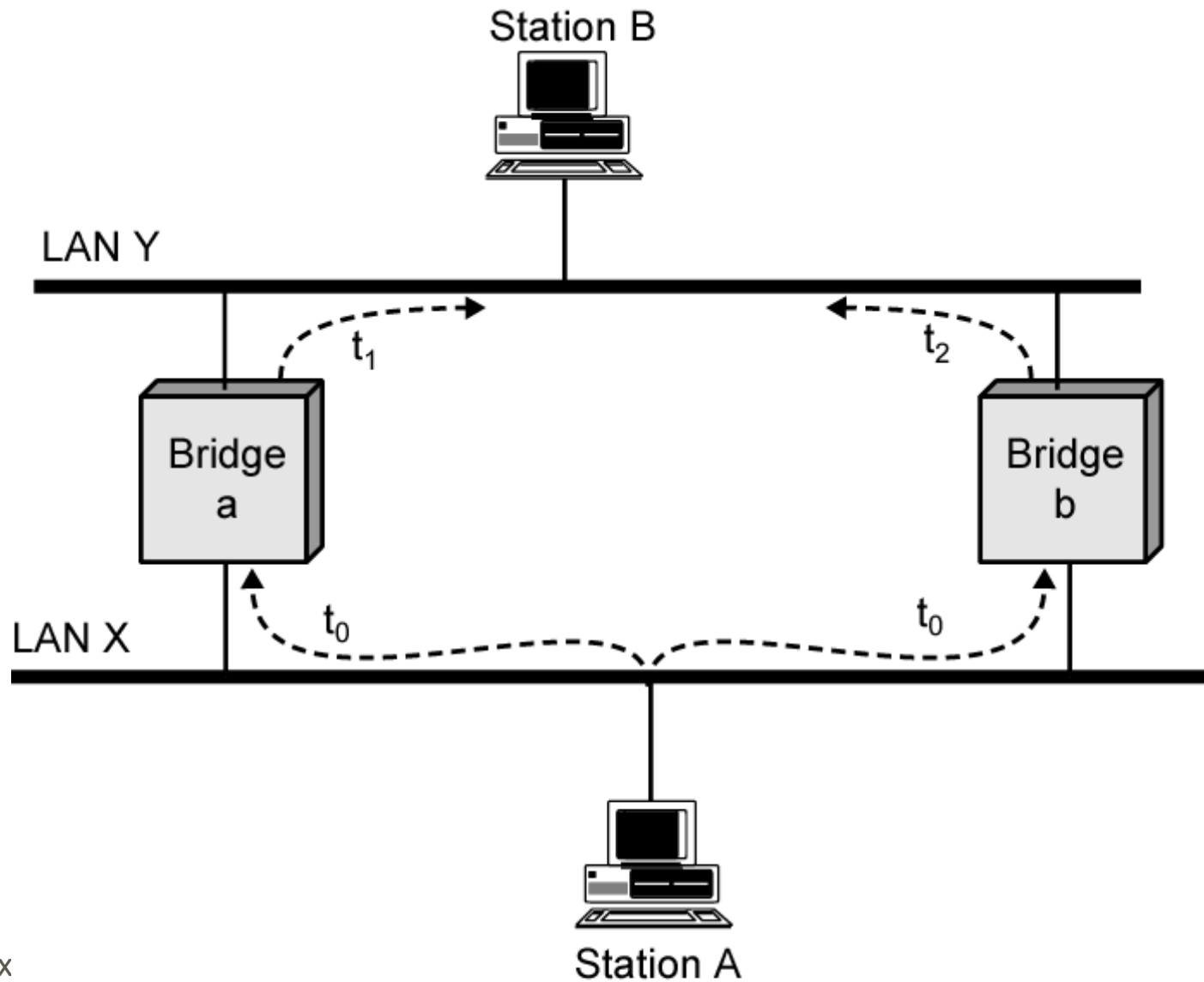

Layer 2 and Layer 3 Switches

- Now many types of devices for interconnecting LANs
- Beyond bridges and routers
- Layer 2 switches
- Layer 3 switches

Hubs

- Active central element of star layout
- Each station connected to hub by two lines
 - Transmit and receive
- Hub acts as a repeater
- When single station transmits, hub repeats signal on outgoing line to each station
- Line consists of two unshielded twisted pairs
- Limited to about 100 m
 - High data rate and poor transmission qualities of UTP
- Optical fiber may be used
 - Max about 500 m
- Physically star, logically bus
- Transmission from any station received by all other stations
- If two stations transmit at the same time, collision

Hub Layouts

- Multiple levels of hubs cascaded
- Each hub may have a mixture of stations and other hubs attached to from below
- Fits well with building wiring practices
 - Wiring closet on each floor
 - Hub can be placed in each one
 - Each hub services stations on its floor

Two Level Star Topology

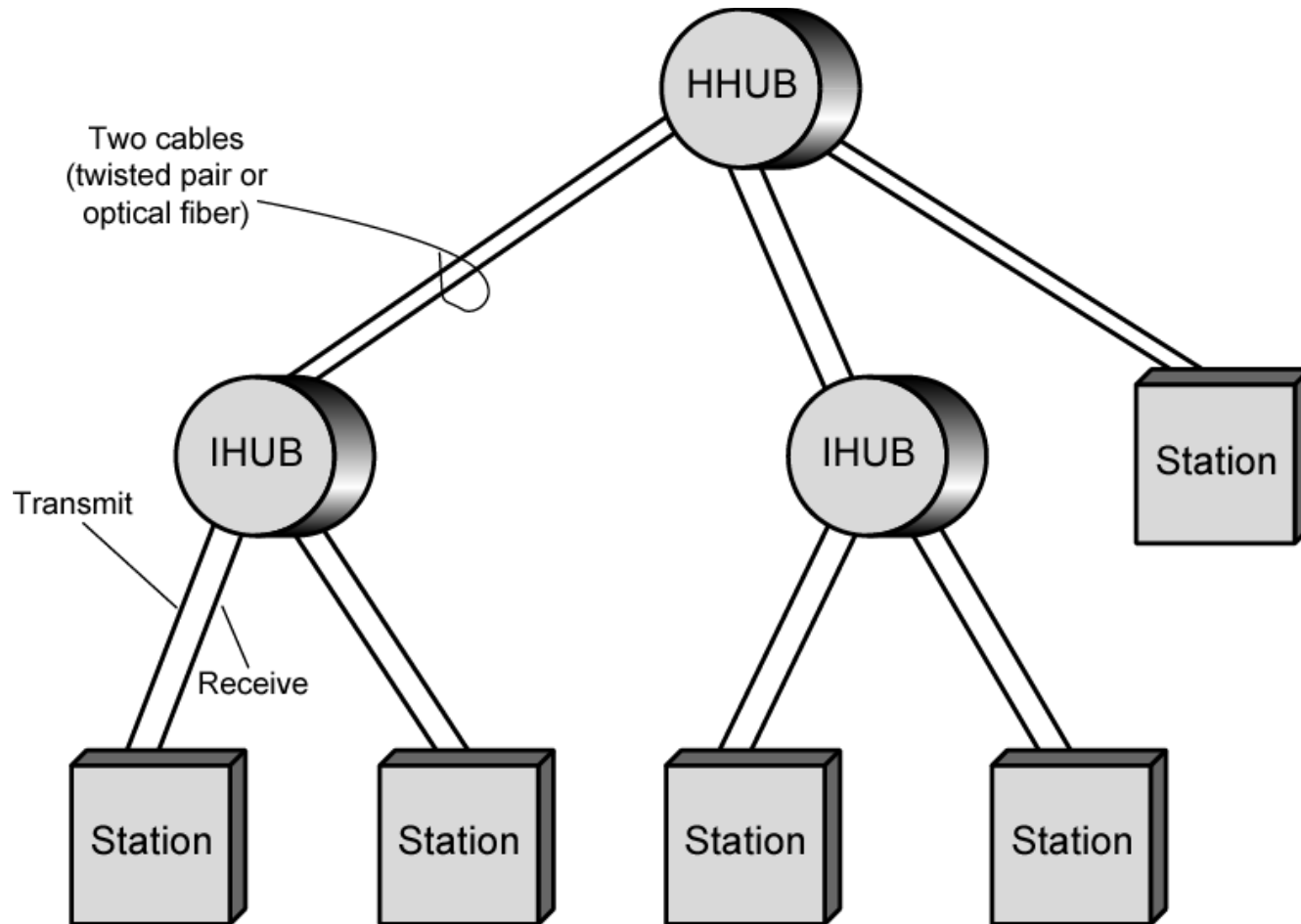

Buses and Hubs

- Bus configuration
 - All stations share capacity of bus (e.g. 10Mbps)
 - Only one station transmitting at a time
- Hub uses star wiring to attach stations to hub
 - Transmission from any station received by hub and retransmitted on all outgoing lines
 - Only one station can transmit at a time
 - Total capacity of LAN is 10 Mbps
- Improve performance with layer 2 switch

Shared Medium Bus and Hub

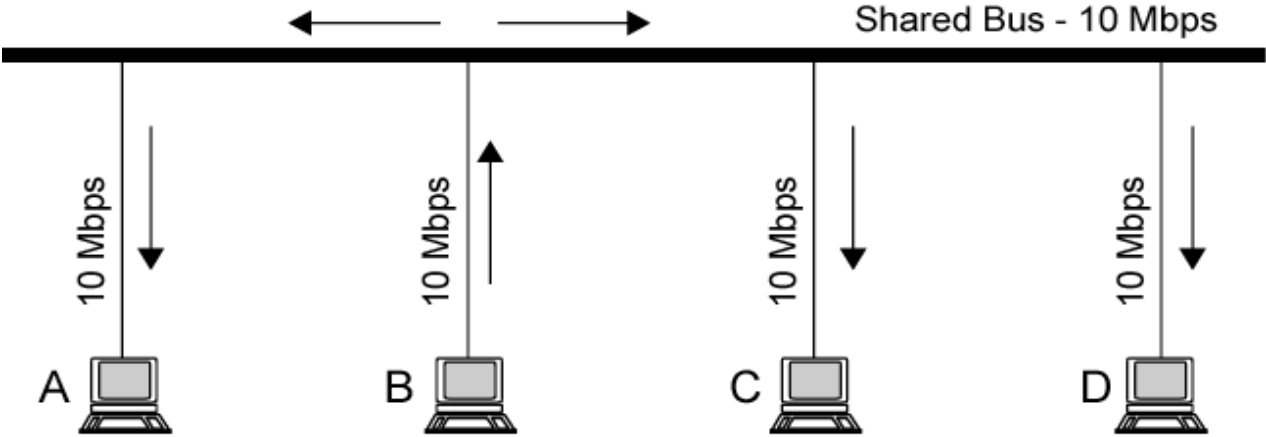

(a) Shared medium bus

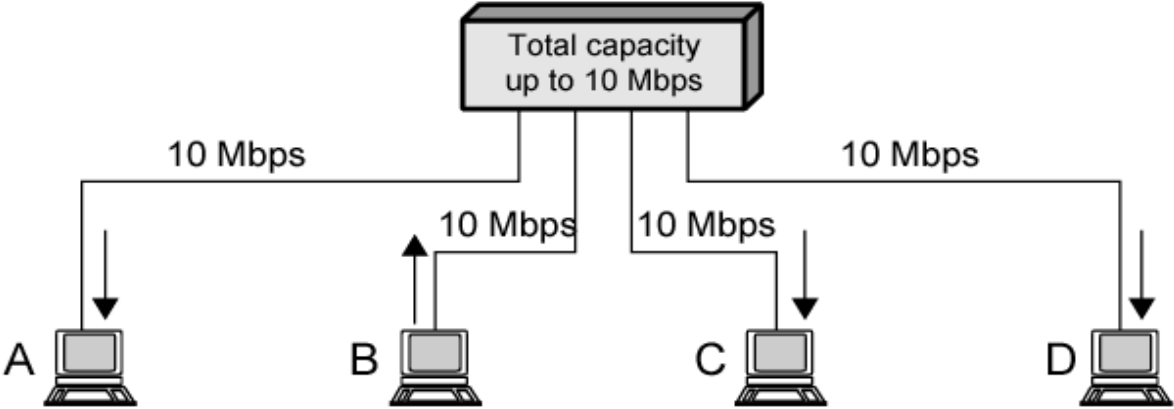

(b) Shared medium hub

Shared Medium Hub and Layer 2 Switch

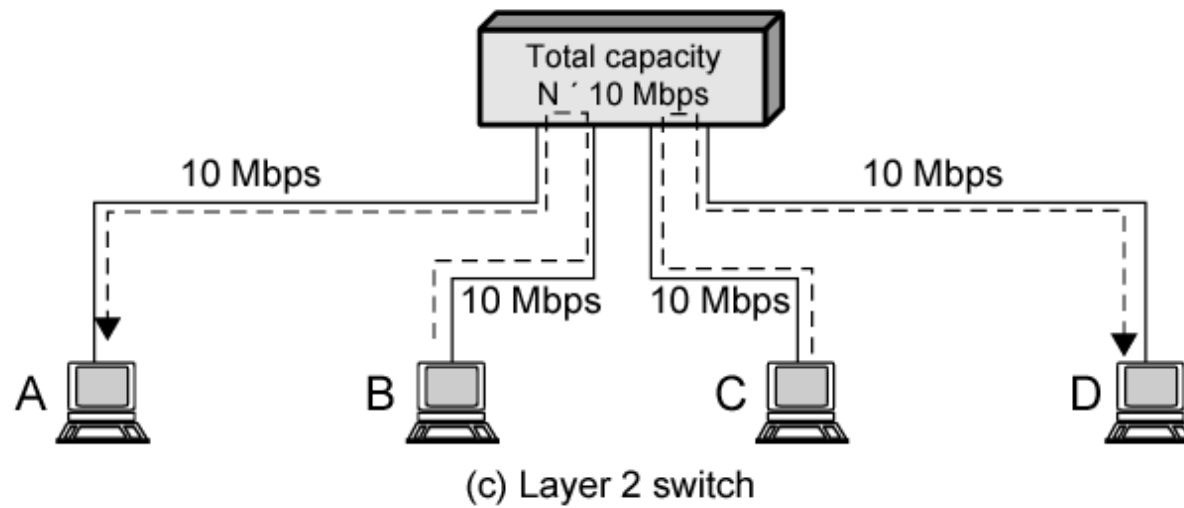
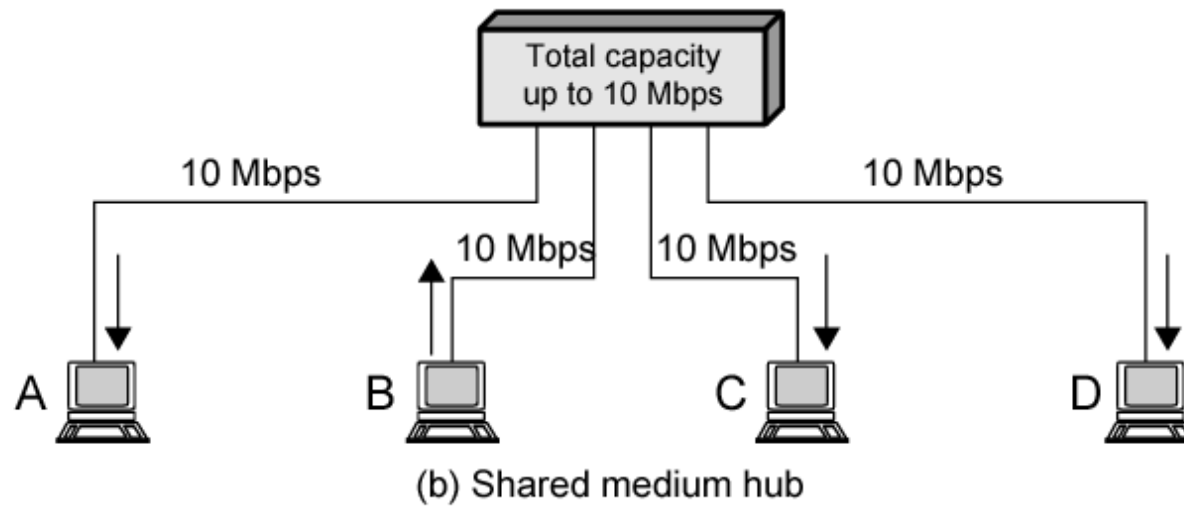

Layer 2 Switches

- Central hub acts as switch
- Incoming frame from particular station switched to appropriate output line
- Unused lines can switch other traffic
- More than one station transmitting at a time
- Multiplying capacity of LAN

Layer 2 Switch Benefits

- No change to attached devices to convert bus LAN or hub LAN to switched LAN
- For Ethernet LAN, each device uses Ethernet MAC protocol
- Device has dedicated capacity equal to original LAN
 - Assuming switch has sufficient capacity to keep up with all devices
 - For example if switch can sustain throughput of 20 Mbps, each device appears to have dedicated capacity for either input or output of 10 Mbps
- Layer 2 switch scales easily
 - Additional devices attached to switch by increasing capacity of layer 2

Types of Layer 2 Switch

- Store-and-forward switch
 - Accepts frame on input line
 - Buffers it briefly,
 - Then routes it to appropriate output line
 - Delay between sender and receiver
 - Boosts integrity of network
- Cut-through switch
 - Takes advantage of destination address appearing at beginning of frame
 - Switch begins repeating frame onto output line as soon as it recognizes destination address
 - Highest possible throughput
 - Risk of propagating bad frames
 - Switch unable to check CRC prior to retransmission

Layer 2 Switch v Bridge

- Layer 2 switch can be viewed as full-duplex hub
- Can incorporate logic to function as multiport bridge
- Bridge frame handling done in software
- Switch performs address recognition and frame forwarding in hardware
- Bridge only analyzes and forwards one frame at a time
- Switch has multiple parallel data paths
 - Can handle multiple frames at a time
- Bridge uses store-and-forward operation
- Switch can have cut-through operation
- Bridge suffered commercially
 - New installations typically include layer 2 switches with bridge functionality rather than bridges

Problems with Layer 2 Switches (1)

- As number of devices in building grows, layer 2 switches reveal some inadequacies
- Broadcast overload
- Lack of multiple links
- Set of devices and LANs connected by layer 2 switches have flat address space
 - All users share common MAC broadcast address
 - If any device issues broadcast frame, that frame is delivered to all devices attached to network connected by layer 2 switches and/or bridges
 - In large network, broadcast frames can create big overhead
 - Malfunctioning device can create broadcast storm
 - Numerous broadcast frames clog network

Problems with Layer 2 Switches (2)

- Current standards for bridge protocols dictate no closed loops
 - Only one path between any two devices
 - Impossible in standards-based implementation to provide multiple paths through multiple switches between devices
 - Limits both performance and reliability.
- Solution: break up network into subnetworks connected by routers
- MAC broadcast frame limited to devices and switches contained in single subnetwork
- IP-based routers employ sophisticated routing algorithms
 - Allow use of multiple paths between subnetworks going through different routers

Problems with Routers

- Routers do all IP-level processing in software
 - High-speed LANs and high-performance layer 2 switches pump millions of packets per second
 - Software-based router only able to handle well under a million packets per second
- Solution: layer 3 switches
 - Implement packet-forwarding logic of router in hardware
- Two categories
 - Packet by packet
 - Flow based

Packet by Packet or Flow Based

- Operates in same way as traditional router
- Order of magnitude increase in performance compared to software-based router
- Flow-based switch tries to enhance performance by identifying flows of IP packets
 - Same source and destination
 - Done by observing ongoing traffic or using a special flow label in packet header (IPv6)
 - Once flow is identified, predefined route can be established

Typical Large LAN Organization

- Thousands to tens of thousands of devices
- Desktop systems links 10 Mbps to 100 Mbps
 - Into layer 2 switch
- Wireless LAN connectivity available for mobile users
- Layer 3 switches at local network's core
 - Form local backbone
 - Interconnected at 1 Gbps
 - Connect to layer 2 switches at 100 Mbps to 1 Gbps
- Servers connect directly to layer 2 or layer 3 switches at 1 Gbps
- Lower-cost software-based router provides WAN connection
- Circles in diagram identify separate LAN subnetworks
- MAC broadcast frame limited to own subnetwork

Typical Large LAN Organization Diagram

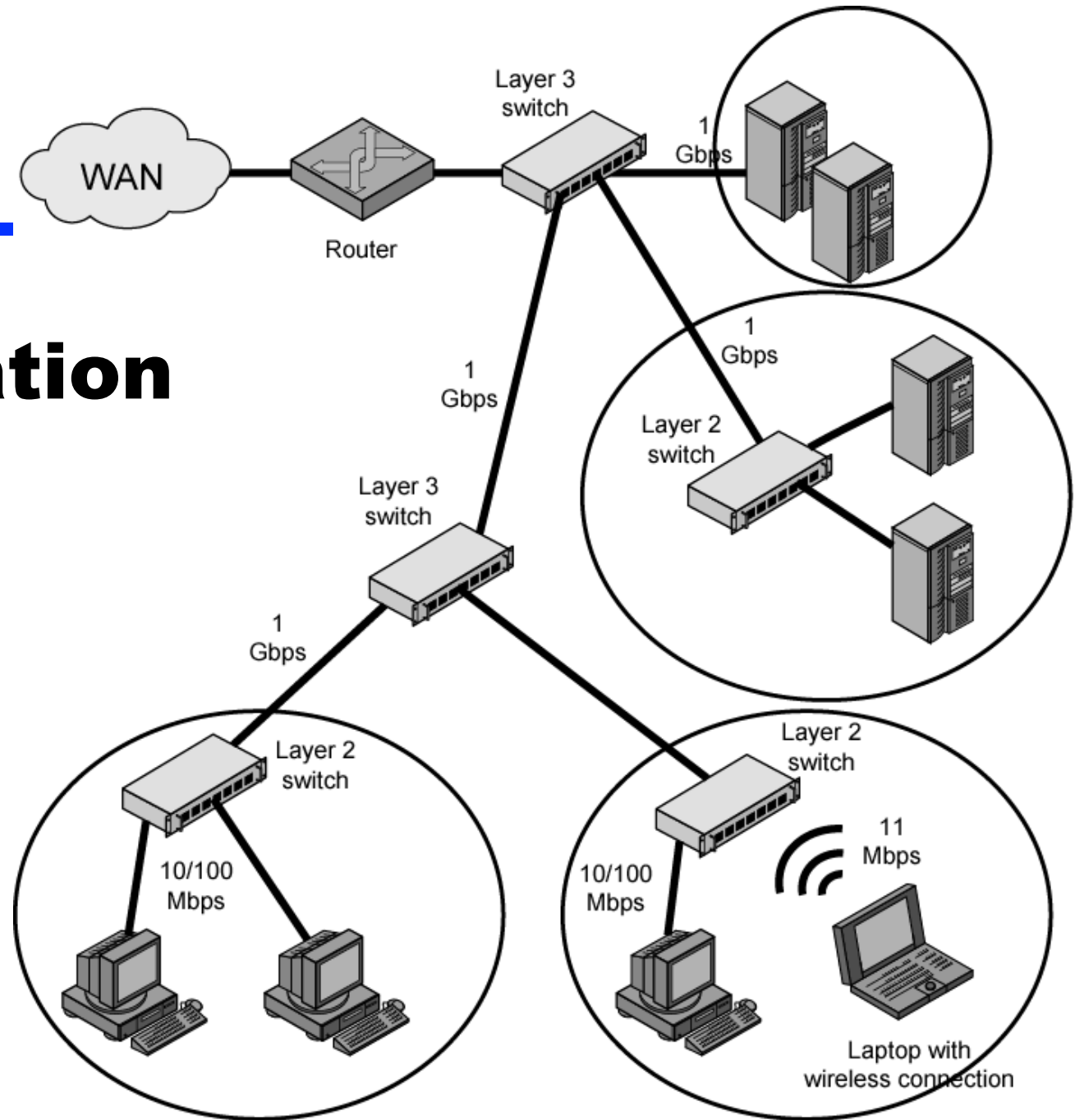

Summary

- LAN topologies and media
- LAN protocol architecture
- bridges, hubs, layer 2 & 3 switches