

Local Area Network Overview

Chapter 11 in Stallings 10th Edition

LAN Applications (1)

- Personal computer LANs
 - Low cost
 - Limited data rate
- Back end networks
 - Interconnecting large systems (mainframes and large storage devices)
 - High data rate
 - High speed interface
 - Distributed access
 - Limited distance
 - Limited number of devices

LAN Applications (2)

- Storage Area Networks
 - Separate network handling storage needs
 - Detaches storage tasks from specific servers
 - Shared storage facility across high-speed network
 - Hard disks, tape libraries, CD arrays
 - Improved client-server storage access
 - Direct storage to storage communication for backup
- High speed office networks
 - Desktop image processing
 - High capacity local storage
- Backbone LANs
 - Interconnect low speed local LANs
 - Reliability
 - Capacity
 - Cost

Storage Area Networks

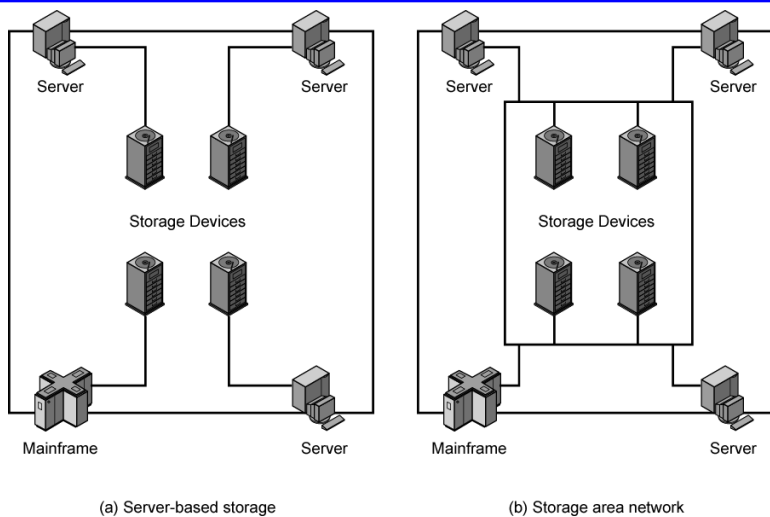

LAN Architecture

- Topologies
- Transmission medium
- Layout
- Medium access control

Bus

- Multipoint medium
- Transmission propagates throughout medium
- Heard by all stations
 - Need to identify target station
 - Each station has unique address
- Full duplex connection between station and tap
 - Allows for transmission and reception
- Need to regulate transmission
 - To avoid collisions
 - To avoid hogging
 - Data in small blocks - frames
- Terminator absorbs frames at end of medium

Frame Transmission on Bus LAN

Figure 11.1

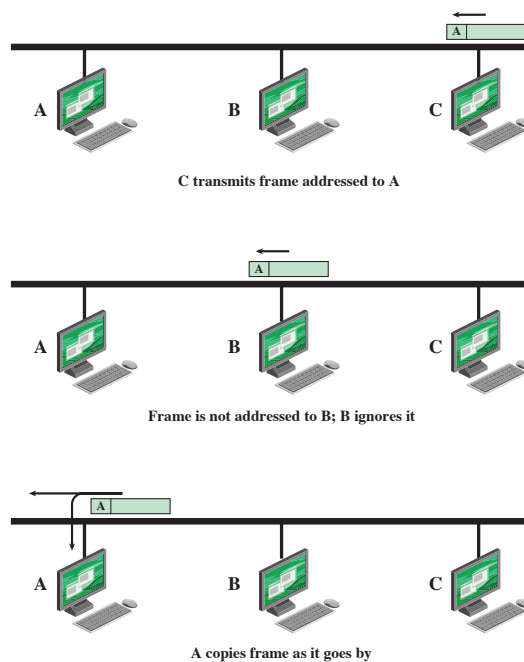

CS420/520 Axel Krings

Star Topology

- Each station connected directly to common central node
 - Usually via two point to point links
- Central node can broadcast
 - Physical star, logical bus
 - Only one station can transmit at a time (hub)
- Central node can act as frame switch

CS420/520 Axel Krings

Page 8

Sequence 11

Star Topology

Figure 11.2

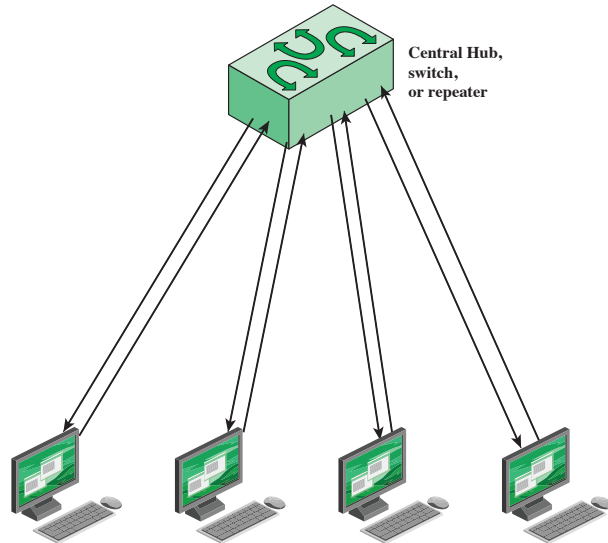

CS420/520 Axel Krings

Protocol Architecture

- Lower layers of OSI model
- IEEE 802 reference model
- Physical
- Logical link control (LLC)
- Media access control (MAC)

CS420/520 Axel Krings

Page 10

Sequence 11

IEEE 802 vs OSI

Figure 1

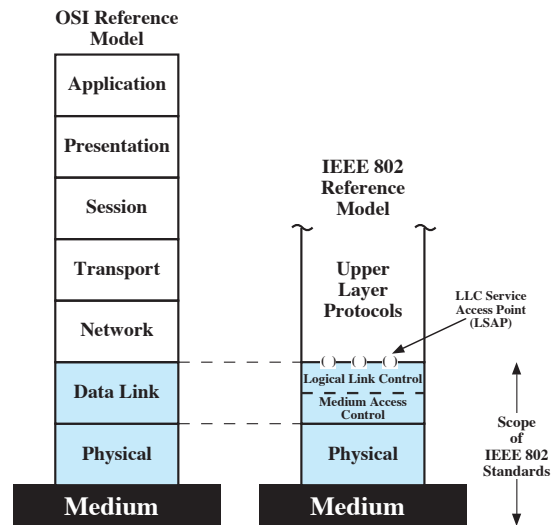

CS420/520 Axel Krir

uence 11

802 Layers - Physical

- Encoding/decoding
- Preamble generation/removal
- Bit transmission/reception
- Transmission medium and topology

CS420/520 Axel Krings

Page 12

Sequence 11

IEEE 802 Layers

- **Logical Link Control Layer (LLC)**
 - Provide interface to higher levels
 - Perform flow and error control
- **Media Access Control (MAC)**
 - On transmit assemble data into frame
 - On reception disassemble frame, perform address recognition and error detection
 - Govern access to LAN transmission medium

LAN Protocols in Context

Figure 11.4

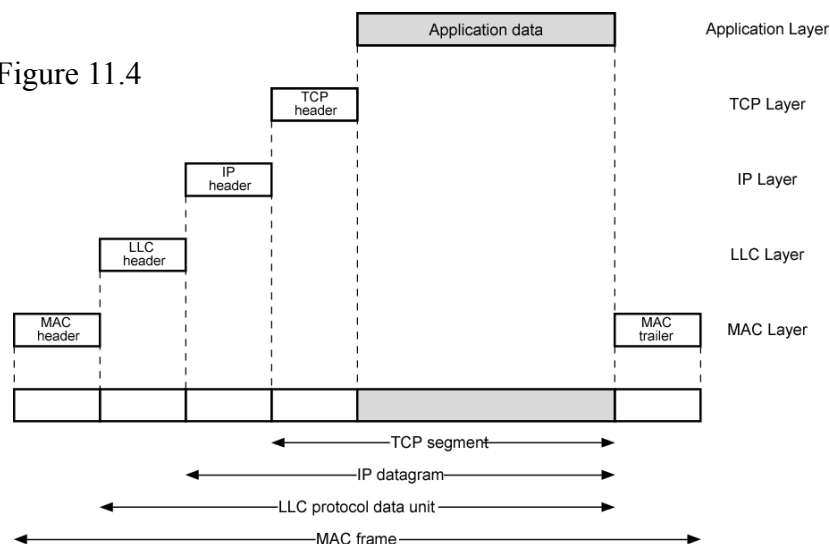

Logical Link Control

- Transmission of link level PDUs between stations
- Must support multi-access, shared medium
- Relieved of some details of link access by the MAC layer
- Addressing involves specifying source and destination LLC users
 - Referred to as service access points (SAPs)

LLC Services

Unacknowledged connectionless service

- Data-gram style service
- Delivery of data is not guaranteed

Connection-mode service

- Logical connection is set up between two users
- Flow and error control are provided

Acknowledged connectionless service

- Datagrams are to be acknowledged, but no logical connection is set up

LLC Service Alternatives

Unacknowledged connectionless service

- Requires minimum logic
- Avoids duplication of mechanisms
- Preferred option in most cases

Connection-mode service

- Used in simple devices
- Provides flow control and reliability mechanisms

Acknowledged connectionless service

- Large communication channel needed
- Time critical or emergency control signals

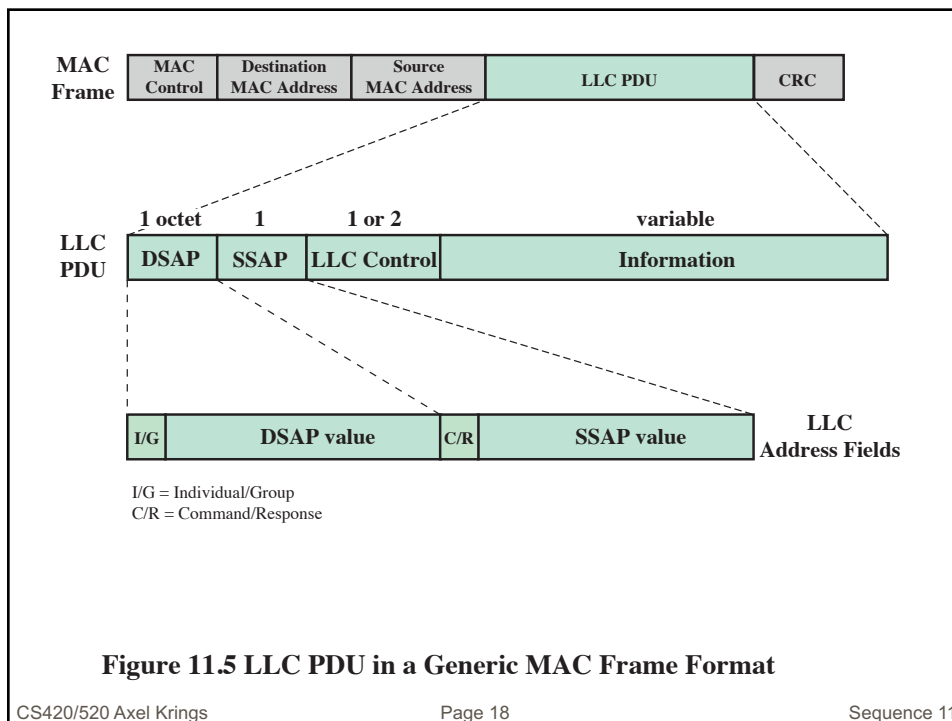

LLC Protocol

- Modeled after HDLC
- Asynchronous balanced mode
 - Connection mode (type 2) LLC service
- Unacknowledged connectionless service
 - Using unnumbered information PDUs (type 1)
- Acknowledged connectionless service
 - Using 2 new unnumbered PDUs (type 3)
- Permits multiplexing using LSAPs

Media Access Control

- Where
 - Central
 - Greater control
 - Simple access logic at station
 - Avoids problems of co-ordination
 - Single point of failure
 - Potential bottleneck
 - Distributed
- How
 - Synchronous
 - Specific capacity dedicated to connection, not optimal
 - Asynchronous
 - In response to demand, round robin, reservation, contention

Asynchronous Systems

- Round robin
 - Good if many stations have data to transmit over extended period
- Reservation
 - Divide medium into slots.
 - Good for stream traffic
- Contention
 - Good for bursty traffic
 - All stations contend for time
 - Distributed
 - Simple to implement
 - Efficient under moderate load
 - Tend to collapse under heavy load

MAC Frame Handling

- MAC layer receives data from LLC layer
- PDU is referred to as a MAC frame
- MAC layer detects errors and discards frames
- LLC optionally retransmits unsuccessful frames

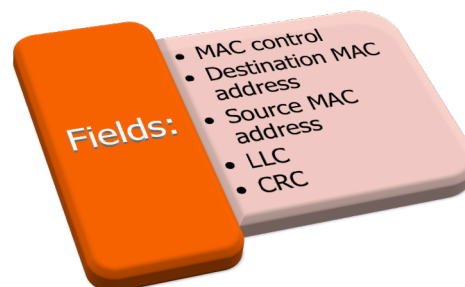

Bridges

- Connects similar LANs with identical physical and link layer protocols
- Minimal processing
- Can map between MAC formats
- Reasons for use:
 - Reliability
 - Performance
 - Security
 - Geography

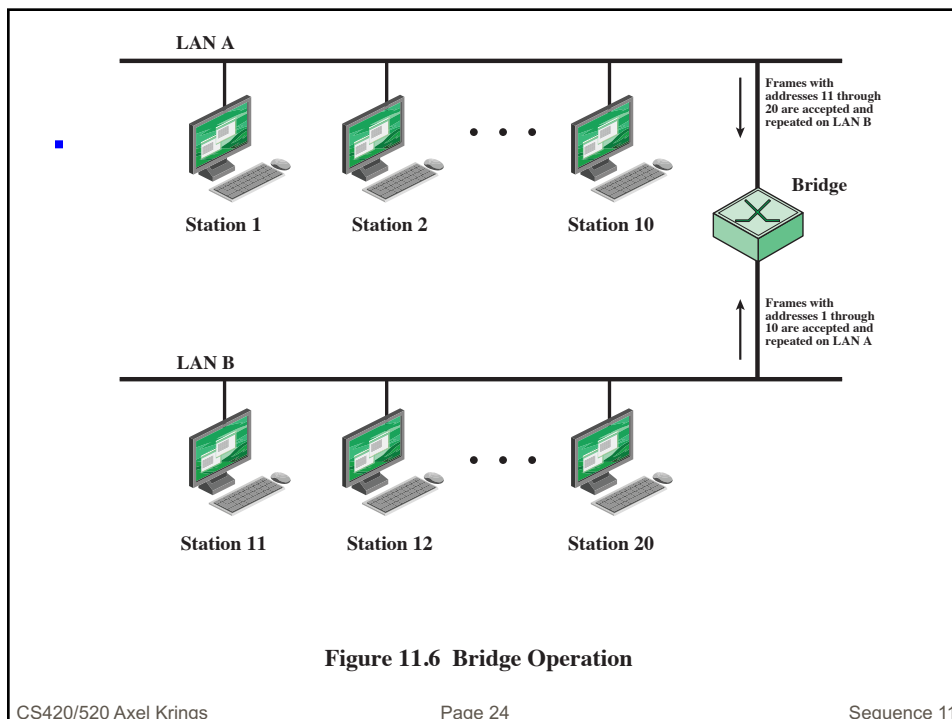

Bridge Design Aspects

- Makes no modification to the content or format of the frames it receives
- Should contain enough buffer space to meet peak demands
- Must contain routing and addressing intelligence
- May connect more than two LANs
- Bridging is transparent to stations

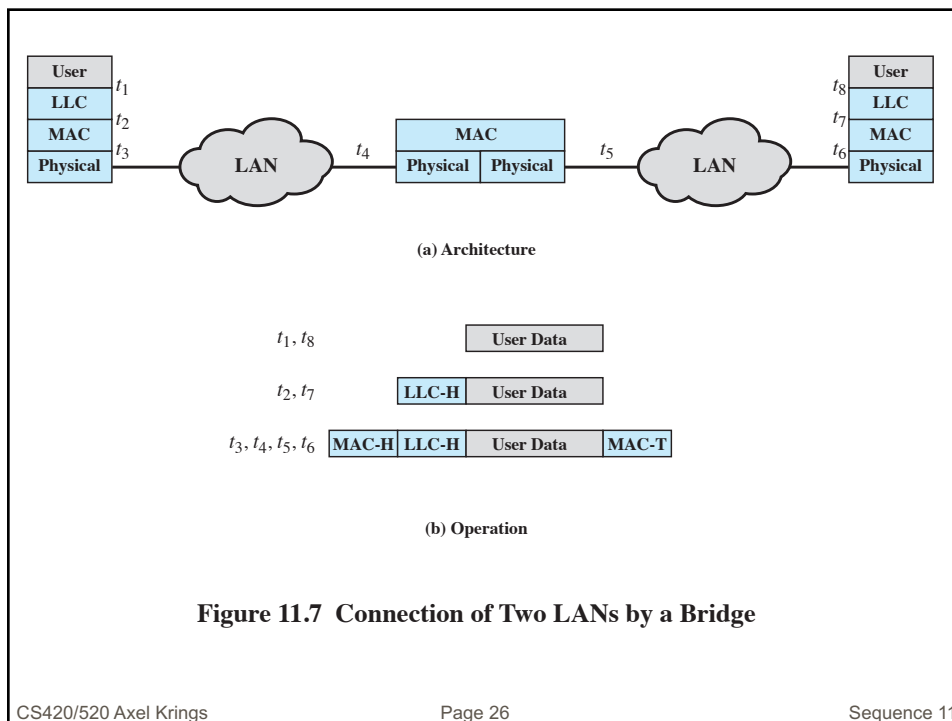

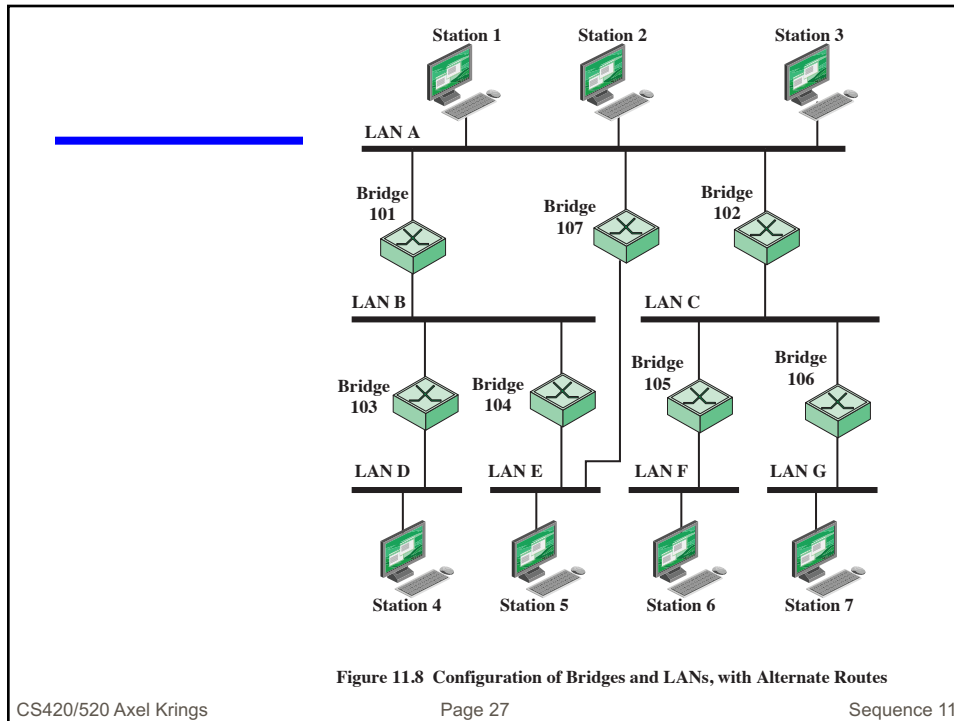

Fixed Routing

- Simplest and most common strategy
- Suitable for small internets and internets that are relatively stable
- A fixed route is selected for each pair of LANs
 - Usually least hop route
- Only change when topology changes
- Widely used but limited flexibility

Spanning Tree

- Bridge automatically develops routing table
- Automatically update in response to changes
- Algorithm consists of 3 mechanisms:
 - Frame forwarding
 - Address learning
 - Loop resolution

Frame forwarding

- Maintain forwarding database for each port
 - List station addresses reached through each port
- For a frame arriving on port X:
 - Search forwarding database to see if MAC address is listed for any port (except port X)
 - If address not found, forward to all ports (except X)
 - If address listed for some port Y, check port Y for blocking or forwarding state
 - Blocking prevents port from receiving or transmitting
 - If Y is not blocked, transmit frame through port Y

Address Learning

- Can preload forwarding database
- When frame arrives at port X, it has come from the LAN attached to port X
- Use source address to update forwarding database for port X to include that address
- Have a timer on each entry in database
 - If timer expires, entry is removed
- Each time frame arrives, source address checked against forwarding database
 - If present timer is reset and direction recorded
 - If not present entry is created and timer set

Spanning Tree Algorithm

- Address learning works for tree layout if there are no alternate routes in the network
 - Alternate route means there is a closed loop
- For any connected graph there is a spanning tree maintaining connectivity with no closed loops
- Algorithm must be dynamic

IEEE 802.1 Spanning Tree Algorithm:

- Each bridge assigned unique identifier
- Cost assigned to each bridge port
- Exchange information between bridges to find spanning tree
- Automatically updated whenever topology changes

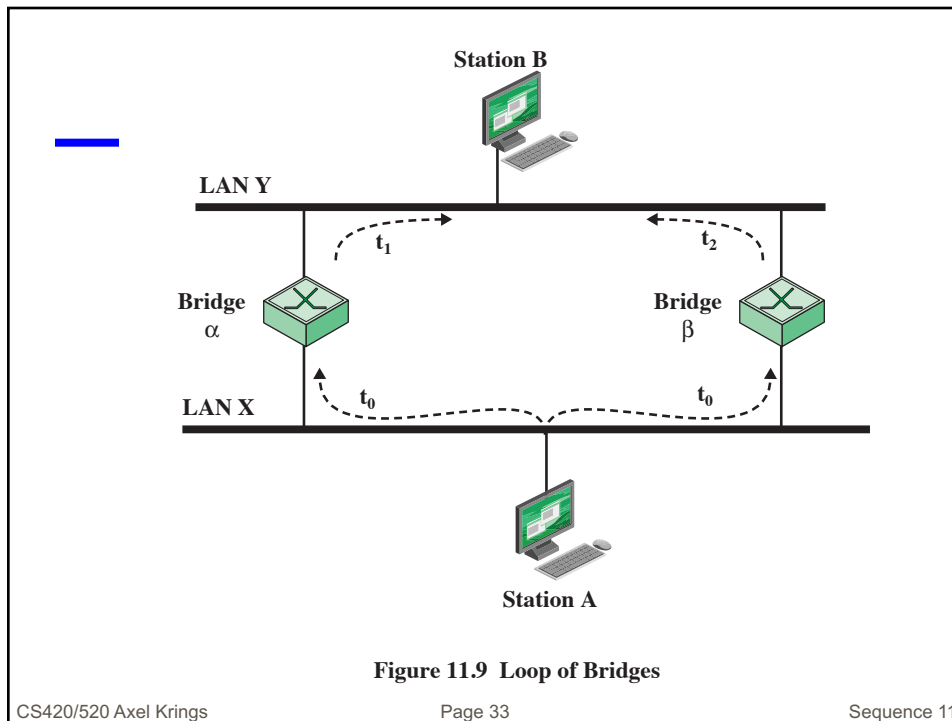

Hubs

- Active central element of star layout
- Each station connected to hub by two lines
- Hub acts as a repeater
- Length of a line is limited to about 100m
- Optical fiber may be used to about 500m
- Physically a star, logically a bus
- Transmission from any one station is received by all other stations
- If two stations transmit at the same time there will be a collision

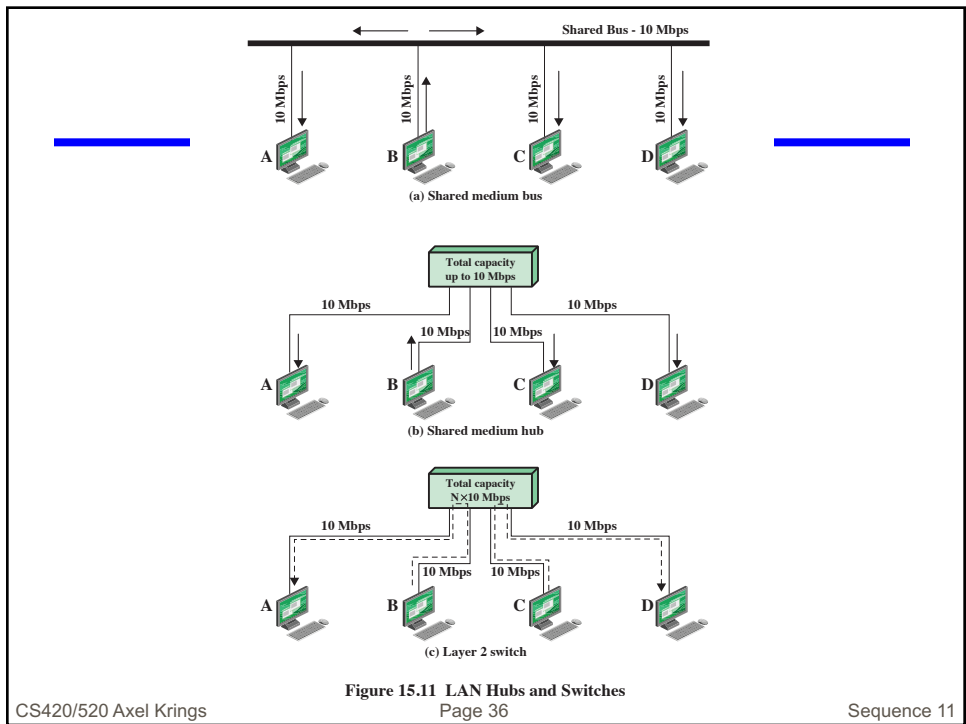
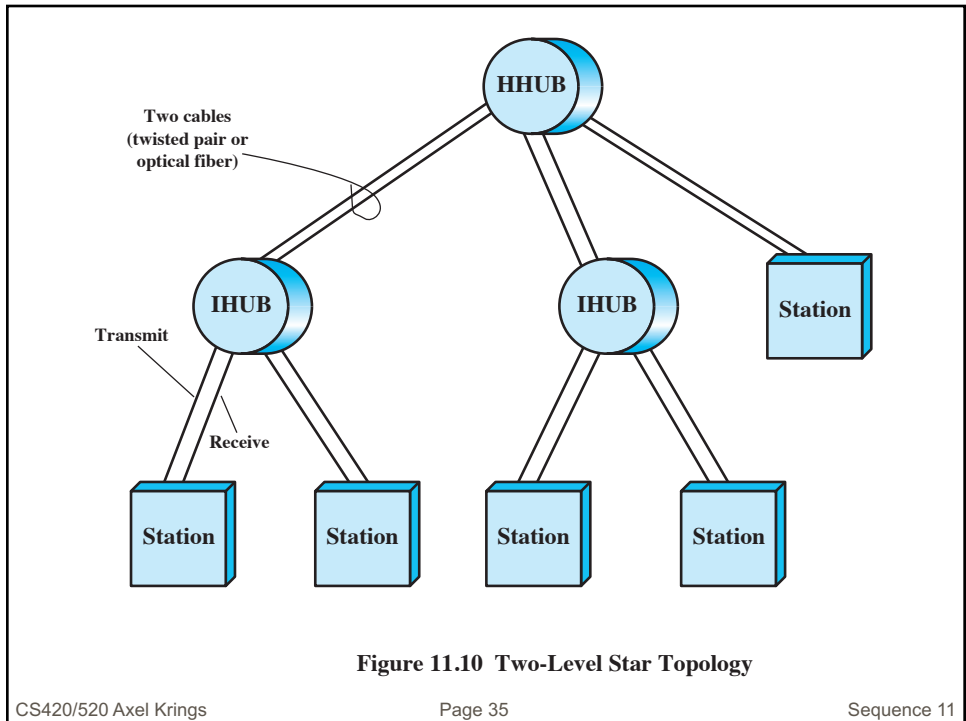

Layer 2 Switch Benefits

- No change is required to the software or hardware of the attached devices to convert a bus LAN or a hub LAN to a switched LAN
- Have dedicated capacity equal to original LAN
 - Assuming switch has sufficient capacity to keep up with all devices
- Scales easily
 - Additional devices attached to switch by increasing capacity of layer 2

Types of Layer 2 Switch

- Store-and-forward switch
 - Accepts frame on input line
 - Buffers it briefly,
 - Then routes it to appropriate output line
 - Delay between sender and receiver
 - Boosts integrity of network
- Cut-through switch
 - Takes advantage of destination address appearing at beginning of frame
 - Switch begins repeating frame onto output line as soon as it recognizes destination address
 - Highest possible throughput
 - Risk of propagating bad frames
 - Switch unable to check CRC prior to retransmission

Layer 2 Switch vs. Bridge

- Differences between switches and bridges:

Bridge

Frame handling done in software

Analyzes and forwards one frame at a time

Uses store-and-forward operation

Switch

Performs frame forwarding in hardware

Can handle multiple frames at a time

Can have cut-through operation

- Layer 2 switch can be viewed as full-duplex hub
- Incorporates logic to function as multiport bridge
- New installations typically include layer 2 switches with bridge functionality rather than bridges

One big LAN

No separation for broadcasts

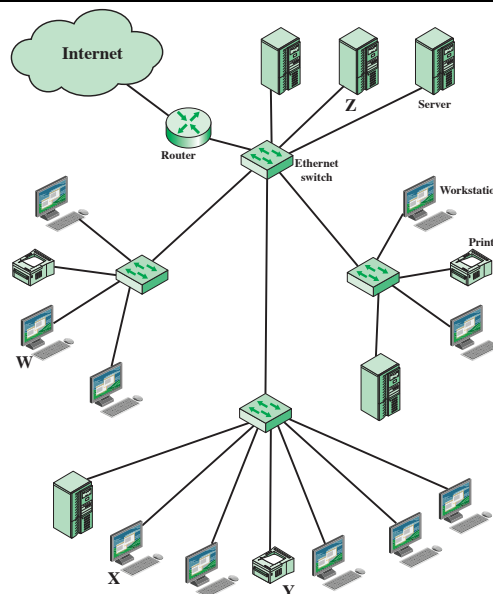

Figure 11.12 A LAN Configuration

Router V:
Now 4 separate LANS

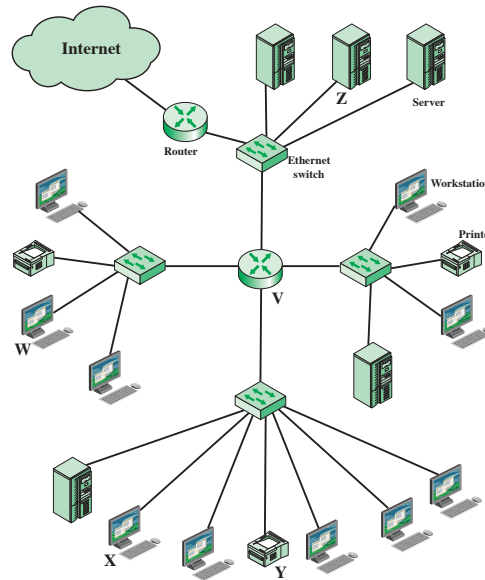

Figure 11.13 A Partitioned LAN

Problems with Routers

- Routers do all IP-level processing in software
 - High-speed LANs and high-performance layer 2 switches pump huge # of packets per second
 - Software-based router are slower
- Solution: layer 3 switches
 - Implement packet-forwarding logic of router in hardware
- Two categories
 - Packet by packet
 - Flow based

VLAN:
(Virtual LAN)

Logical subgroup
within LAN

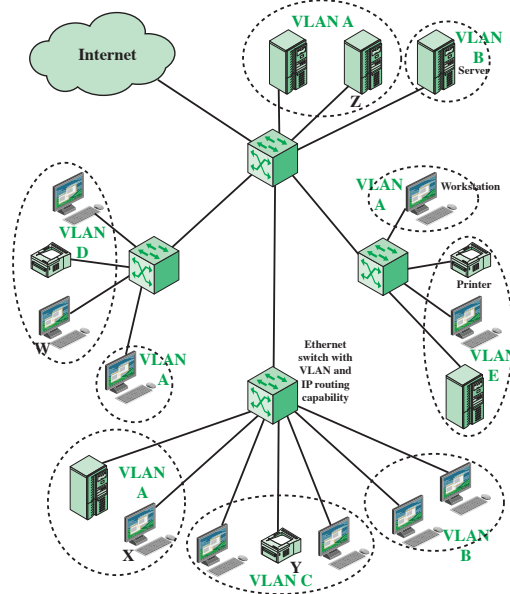

Figure 11.14 A VLAN Configuration

Defining VLANs

- Broadcast domain consisting of a group of end stations not limited by physical location and communicate as if they were on a common LAN
- Membership by:
 - Port group
 - MAC address
 - Protocol information

Communicating VLAN Membership

Switches need to know VLAN membership

- Configure information manually
- Network management signaling protocol
- Frame tagging (IEEE802.1Q)

Summary

- Bus and tree topologies and transmission media
 - Topologies
 - Choice of topology
 - Choice of transmission medium
- LAN protocol architecture
 - IEEE 802 reference model
 - Logical link control
 - Medium access control
- Hubs and switches
 - Hubs
 - Layer 2 switches
- Bridges
 - Functions of a bridge
 - Bridge protocol architecture
 - Fixed routing
 - The spanning tree approach
- Virtual LANs
 - The use of virtual LANs
 - Defining VLANs
 - Communicating VLAN membership